

Ar, He Gas regenerable gas purifier.

5-nines to 9-nines grade purity, with N2 removal.

Platform No.	Flow Rate (Nm3/Hr)	Gas Purified :	Impurities Removed :
FT5	10 to 200	Ar, He	H2O, O2, H2, CO, CO2, CH4, N2 to < 1 ppb

Platform and Flow Diagram

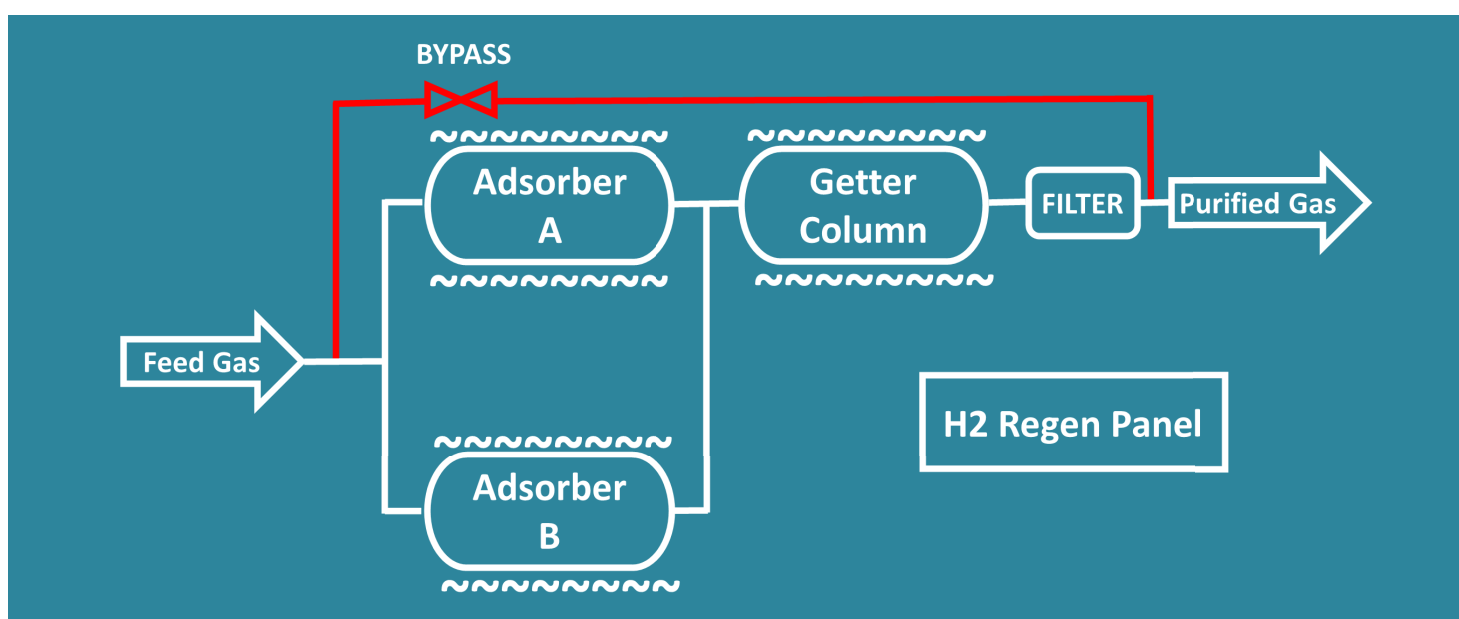

Features Table

Instrumentation	Standard	Optional	Instrumentation	Standard	Optional
12" Touchscreen HMI.	√		Inlet and Outlet Actuated Isolation Valve.	√	
Fully Automatic by the Programmable Logic Controller.	√		Inlet and Outlet Pressure Transducer.		√
Emergency Off Button (EMO).	√		Inlet and Outlet Analytical Port.	√	
Separate Control Power. 110 VAC or 220 VAC or 24 VDC.		√	Flow Meter / Flow Totalizer.		√
Emergency Remote Shutdown.	√		Auto / Manual Bypass Valve.		√
MODBUS with Ethernet Output, RJ45 Connect.	√		Hydrogen Leak Detector. (H2 mixed for regeneration)		√
UPS for Separate Control Power.		√	Overpressure and Getter Protection Relief.	√	
Alarm Light Tower.		√	Instrument Air Management System, with IA reservoir.	√	
			Particle Filtration. (Metal or Teflon Filtration)		√