



Specialty Gas regenerable gas purifier.

5-nines to 9-nines grade purity.

Platform No.	Flow Rate (Nm3/Hr)	Gas Purified :	Impurities Removed :
FT4	10 to 500	Specialty Gas	H2O and O2 to < 1 ppb.

Platform and Flow Diagram

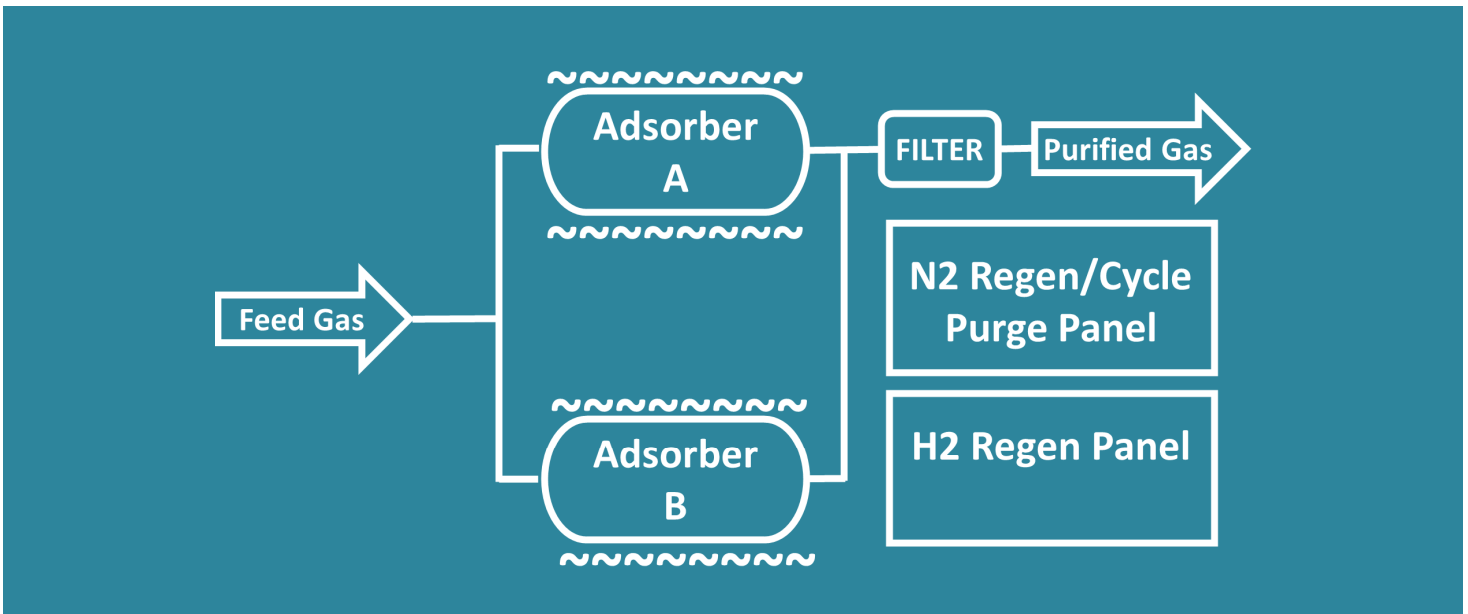

Features Table

Instrumentation	Standard	Optional	Instrumentation	Standard	Optional
12" Touchscreen HMI	√		Inlet and Outlet Actuated / Manual Isolation Valve.		√
Fully Automatic by the Programmable Logic Controller.	√		Inlet and Outlet Pressure Transducer.	√	
Emergency Off Button (EMO).	√		Inlet and Outlet Analytical Port.	√	
Separate Control Power. 110 VAC or 220 VAC or 24 VDC.		√	Flow Meter / Flow Totalizer.		√
Emergency Remote Shutdown	√		Z-Purge for Electrical Cabinet		√
MODBUS with Ethernet Output, RJ45 Connect.	√		Gas Leak Detector.		√
UPS for Separate Control Power.		√	Overpressure Relief Protection.	√	
Alarm Light Tower.		√	Instrument Air Management System, with IA reservoir.	√	
		√	Particle Filtration. (Metal or Teflon Filtration)		√