

# GETTRON, GT3

## 80 slpm, Getter Type Gas Purifiers

GETTRON® series GT3-R/N/H purifier is a Getter-Based purifier designed for analytical and semiconductor applications. Heated getter technology to remove impurities to 1 ppb levels for Nitrogen, Hydrogen and Rare Gases with up to 80 slpm flow rate.

Operated by a PLC and featuring a user-friendly 4.3" touchable color HMI, the GT3 Purifier ensures steadfast stability and control. Furthermore, it offers MODBUS protocol for seamless integration into customer SCADA systems.

### Applications

- ✓ Analytical zero and carrier gas
- ✓ Annealing cover gases
- ✓ Crystal pulling
- ✓ MOCVD
- ✓ Optical fiber manufacturing
- ✓ Pharmaceutical production
- ✓ Photolithography
- ✓ PVD, CVD
- ✓ Welding and Purging
- ✓ Silicon epitaxy
- ✓ Semiconductor equipment
- ✓ Welding and Purging



Standard Features	Performance						
	PURIFY GAS	NITROGEN		ARGON / HELIUM		HYDROGEN	
Controller	IMPURITIES	INLET	OUTLET	INLET	OUTLET	INLET	OUTLET
✓ Fully Automated Controller by Programmable Logic Controller.							
✓ 4.3" Touchable Human Machine Interface.	H2O	<1.0 ppmv	≤ 1.0 ppbv	<1.0 ppmv	≤ 1.0 ppbv	<1.0 ppmv	≤ 1.0 ppbv
✓ PLC MODBUS Communication Port, Ethernet, RJ45 Connector.	O2	<1.0 ppmv	≤ 1.0 ppbv	<1.0 ppmv	≤ 1.0 ppbv	<1.0 ppmv	≤ 1.0 ppbv
<b>Gas Panel &amp; Hardware</b>	CO	<0.5 ppmv	≤ 1.0 ppbv	<0.5 ppmv	≤ 1.0 ppbv	<0.5 ppmv	≤ 1.0 ppbv
✓ Inlet, Outlet and Bypass Actuated Valves.	CO2	<0.5 ppmv	≤ 1.0 ppbv	<0.5 ppmv	≤ 1.0 ppbv	<0.5 ppmv	≤ 1.0 ppbv
✓ Over Pressure Safety Vent.	H2	<0.5 ppmv	≤ 1.0 ppbv	<0.5 ppmv	≤ 1.0 ppbv	N/A	N/A
✓ Hydrogen Removal Unit. (N2 and Rare Gas models only)	CH4	<0.25 ppmv	≤ 1.0 ppbv	<0.25 ppmv	≤ 1.0 ppbv	N/A	N/A
✓ 0.003µm Particle Filter, Metal.	N2	N/A	N/A	<1.0 ppmv	≤ 1.0 ppbv	<1.0 ppmv	≤ 1.0 ppbv
✓ Metal Enclosure.	Particle		0.1µm ≤ 1ppcf		0.1µm ≤ 1ppcf		0.1µm ≤ 1ppcf



## Numbering System

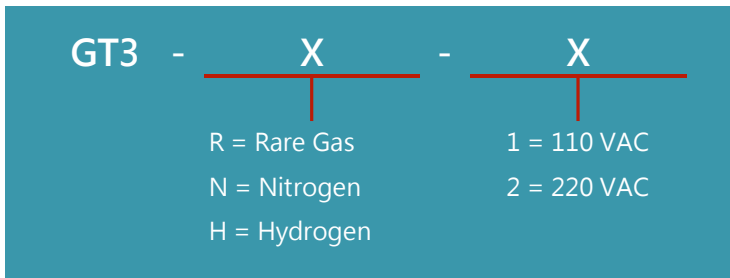

Specifications			
PURIFY GAS	NITROGEN	ARGON / HELIUM	HYDROGEN
MODEL NO.	GT3-N-1/2	GT3-R-1/2	GT3-H-1/2
Maximum Flow	80 slpm	80 slpm	80 slpm
Purified Outlet Filter	0.003 μm metal filter	0.003 μm metal filter	0.003 μm metal filter
Pressure Drop (at 100 psig inlet pressure)	< 7 psid @ Maximum Flow	< 7 psid @ Maximum Flow	< 7 psid @ Maximum Flow
Operation Temperature	300 Celius	350 Celius	300 Celius
Outlet Gas Temperature	<50 °C @ Maximum Flow	<50 °C @ Maximum Flow	<50 °C @ Maximum Flow
Installation Information			
Height (mm)	950 mm	950 mm	950 mm
Width (mm)	300 mm	300 mm	300 mm
Depth (mm)	300 mm	300 mm	300 mm
Weight	41 Kg	41 Kg	42 Kg
Installed Power, GT3_-1	110 VAC, 1P+E, 600 W	110 VAC, 1P+E, 600 W	110 VAC, 1P+E, 600 KW
Installed Power, GT3_-2	220 VAC, 1P+E, 1,000 W	220 VAC, 1P+E, 1,000 W	220 VAC, 1P+E, 1,000 W
Data Output Communication	RJ45/Ethernet, MODBUS	RJ45/Ethernet, MODBUS	RJ45/Ethernet, MODBUS
Inlet & Outlet Gas Connection	1/4" MVCR	1/4" MVCR	1/4" FVCR
Inlet Gas Pressure Range	3.5 ~ 9.8 barg (50 ~ 142 psig)	3.5 ~ 9.8 barg (50 ~ 142 psig)	3.5 ~ 9.8 barg (50 ~ 142 psig)
Instrument Air Connection	1/4" Quick Plug	1/4" Quick Plug	1/4" Quick Plug
Instrument Air Pressure Range	4.1 ~ 6.9 barg (60 ~ 100 psig)	4.1 ~ 6.9 barg (60 ~ 100 psig)	4.1 ~ 6.9 barg (60 ~ 100 psig)
Over Pressure Relief Vent	N/A	N/A	1/4" Compression Fitting
Purifier Housing Exhaust (Facilities Vacuum: 0.2 inches H2O)	4" duct	4" duct	4" duct
Tube Surface Treatment	SUS316L-BA, and EP after getter cartridge	SUS316L-BA, and EP after getter cartridge	SUS316L-BA, and EP after getter cartridge
Pressure Vessel Design Code	ASME Vessel Standards Section VIII CE Marking GB150/SQLO Chinese Vessel Standards	ASME Vessel Standards Section VIII CE Marking GB150/SQLO Chinese Vessel Standards	ASME Vessel Standards Section VIII CE Marking GB150/SQLO Chinese Vessel Standards

# GT3-H, Gas Flow Diagram and Installation Information

## GT3-H, Installation Information

- |                                  |                 |
|----------------------------------|-----------------|
| 1 Feed Gas Inlet Connection      | 1/4" MVCR       |
| 2 Purified Gas Outlet Connection | 1/4" MVCR       |
| 3 Over Pressure Relief Vent      | 1/4" SWG        |
| 4 Exhaust                        | 4" Duct         |
| 5 HMI, 4.3"                      |                 |
| 6 Instrument Air Connection      | 1/4" Quick Plug |
| 7 Communication Port             | RJ45 / Ethernet |
| 8 Main Power Connection Port     |                 |

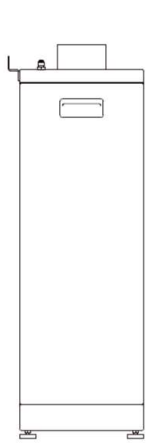
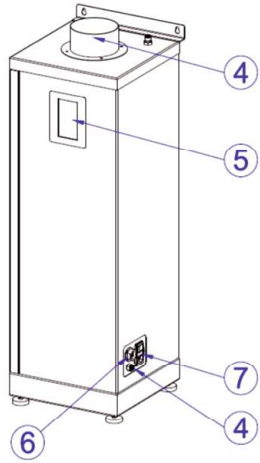

LEFT VIEW

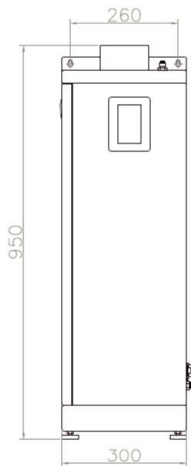

FRONT VIEW

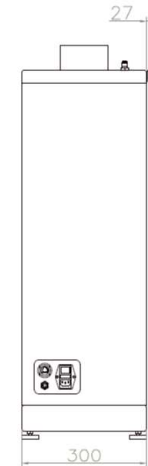

RIGHT VIEW

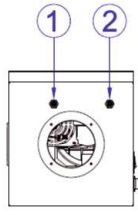

TOP VIEW

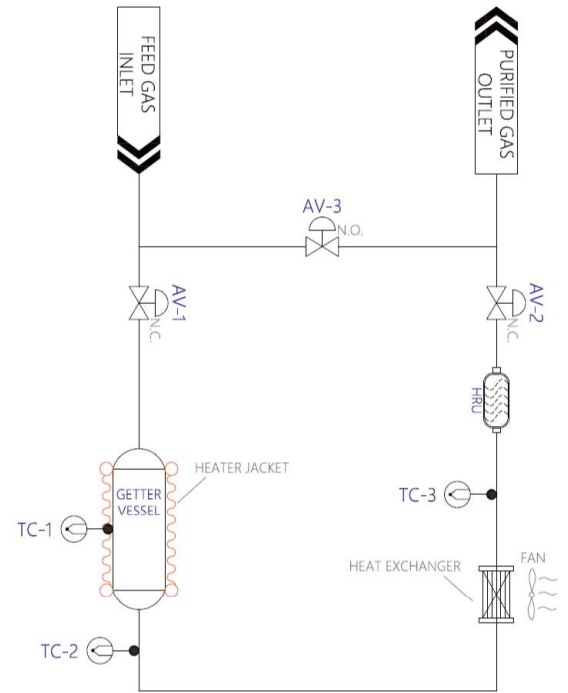

# GT3-R/N, Gas Flow Diagram and Installation Information

## GT3-R/N, Installation Information

- |                                  |                 |
|----------------------------------|-----------------|
| 1 Feed Gas Inlet Connection      | 1/4" MVCR       |
| 2 Purified Gas Outlet Connection | 1/4" MVCR       |
| 3 Exhaust                        | 4" Duct         |
| 4 HMI, 4.3"                      |                 |
| 5 Instrument Air Connection      | 1/4" Quick Plug |
| 6 Communication Port             | RJ45 / Ethernet |
| 7 Main Power Connection Port     |                 |

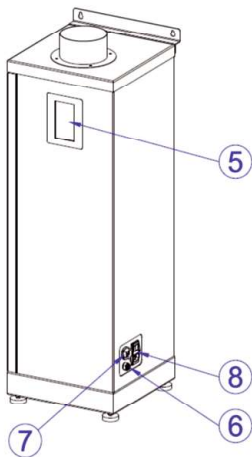

LEFT VIEW

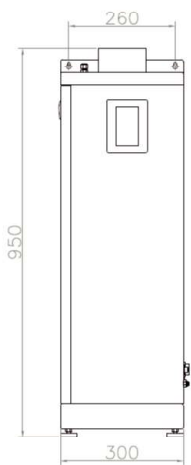

FRONT VIEW

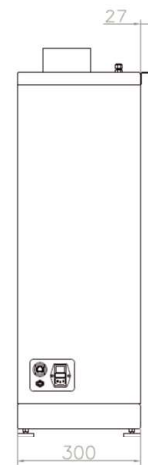

RIGHT VIEW

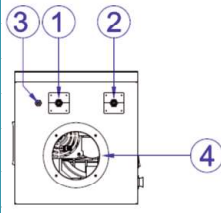

TOP VIEW

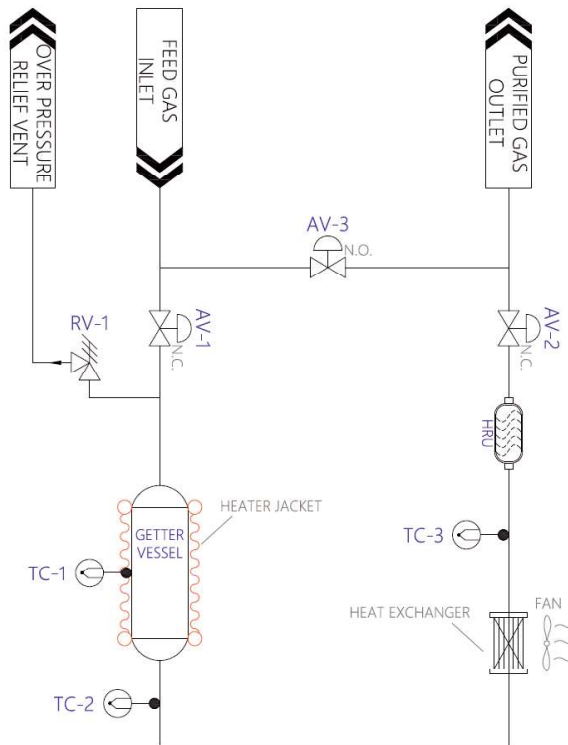

芯動能設備股份有限公司

300075 台灣新竹市香山區中華路四段518-1號五樓

TEL.: +886-3-5160267

FAX: +886-3-5160276

Tronic Purity, Inc.

5F, No.518-1, Sec. 4, Zhonghua Rd., Xiangshan Dist.  
Hsin-Chu City, 300075. Taiwan, R.O.C.

<http://www.tronicpurity.com>

E-mail: [info@tronicpurity.com](mailto:info@tronicpurity.com)

